

ICECUBES IN ROCKETS: A Future History of Human Folly

...is a cautionary tale with surprising twists and turns...

Year 2028: The secret of immortality is discovered. One giant leap for Mankind. One giant leap backwards.

Year 2030: An environmentally friendly renewable fuel is discovered - and is ruthlessly suppressed by Big Business - so as not to threaten their vested interests.

Year 2041: The world has nearly run out of petroleum. America liberates the impoverished nation of Burkina Faso in the name of Freedom and Democracy (it is mere coincidence that massive deposits of uranium were recently discovered there).

Year 2048: America wins the race to Mars! Only thing is, it turns out not to be a race. And not to Mars.

Years 2049-2068: The leaders of the Great Nations of the World proceed to flush Mankind down the swirling plughole of oblivion. Not all is irredeemably bleak however. A handful of heroic individuals manage to cling on to the rim despite the self serving agendas of their bureaucratic administrators. A romance blossoms in unlikely circumstances.

Year 2068: Global Armageddon!! The end of humanity? Perhaps, perhaps not...

Somewhere floating about is a piece of shit which takes on a critical role as events unfold...

A parallel fable is interwoven: A Stranger wakes in Purgatory. Has he died and is he midway between heaven and hell? Or is he someplace else altogether? Who are the people with blue skin? Is the Overlord really the avatar of God Almighty the Creator? Who or what are the Angels of Vengeance, who float above the ground emanating bone chilling shrieks?

Read excerpts at www.rationalist.com.au (issue 67)

(some names have since been changed to include a joke with a time delay fuse)

About the novel:

"Icecubes" is a hard hitting, hysterically funny, scathing indictment of the American New World Order.

A tour de force which defies genre: part tragedy, part comedy, part science fiction, part romance - it is these and more.

The novel depicts human dystopias of the near and far future, brought about by political cronyism, nepotism, arrogance and greed; predicated on circumstances operating in the real world right now. Indeed, some scenes are so reminiscent of current world events, they are literally painfully amusing to read.

The author combines influences from Swift, Huxley, Orwell and Vonnegut, using his own pithy concise style, in a no holds barred, rollicking parody of venal politicians and corrupt corporate leaders.

He expounds the important issues of renewable energy, the sociological implications of individual human "immortality", environmental sustainability, biodiversity, the "demonic" male primate hypothesis, terrorism, global mass extinction and the overweening power and belligerence of the world's only hegemon in an entertaining and provocative manner. He uses hypothetical settings relevant to our present situation, adopting a "whimsically serious" and "flippantly cynical" manner.

The characters are varied and quirky, the dialogue is punchy and confronting, the plot is totally credible yet peppered with unpredictable twists and the scenarios are based on well researched science, politics and history.

Violence is employed only in the best possible taste - never gratuitous: there are just four beheadings and only a small amount of cannibalism!

The enigmatic term "icecubes" is not what you may think - all is revealed ultimately.

Repeated readings will reveal ever deeper layers of meaning and subtlety not appreciated at first glance. An absolute gem to spark vigorous discussion at book clubs.

A word of caution though: this book is for thinking readers only!

ICONOCLAST PRESS



AUSTRALIA

About the author:

Robert E. Lee was a Confederate General who fought for the right to enslave people of a different skin colour. He did not write this novel (being long dead). The name Robert L. Lee adopted here is an ironic pseudonym. The author is a Physician who has had (non-medical) essays on matters of practical philosophy published in the Australian Rationalist and Skeptic journals.

This novel is available from:

The Medical Book Centre, 27 Douglas St, Milton, Brisbane

or by mail order at the reduced price of A\$20/- per copy + \$3/- for postage and handling from

Iconoclast Press Australia, PO Box 4027, Eight Mile Plains, Queensland 4113, Australia

A floppy disk with referenced annotations to the novel, the additional essay "Better paradigms for our energy futures: from fossil fuels to *phytofuels* to *photofuels*" and the new chapter "*Killed by a Humungous Fart*" will accompany each book

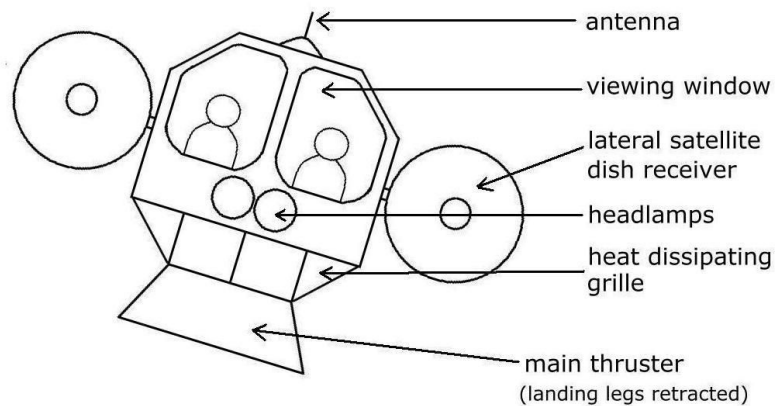

George Bush Jr. AKA Bushbaby:
the face of a primitive monkey

**Harry Potter? Drivel!
The Da Vinci Code? Piffle!
Make way for the first great political satire of
the Twenty First Century:**

